

Alcatel 7330 ISAM FTTN

INTELLIGENT SERVICES ACCESS MANAGER FIBER TO THE NODE



B R O A D E N Y O U R L I F E



The Alcatel 7330 Intelligent Services Access Manager (ISAM) Fiber to the Node (FTTN) takes the best of Alcatel's DSL developments, providing a unique set of capabilities that enables service providers to deliver the most competitive triple play service offerings. Building on Alcatel's leadership in broadband access, the Alcatel 7330 ISAM FTTN addresses the growing need for a deep-fiber access solution. This innovative platform enables service providers to offer IPTV and other ultra-high bandwidth applications while leveraging the existing copper plant. As a member of the ISAM family, the Alcatel 7330 ISAM FTTN shares technology with the Alcatel 7302 ISAM, the industry's first IP-based platform capable of delivering 100 percent triple play services.



The Alcatel Fiber to the Node Solution for Deep-Fiber Access

POWER AND FLEXIBILITY FOR EACH SERVICE PROVIDER'S UNIQUE NEEDS

Alcatel has been the world leader in DSL deployments since the early development of the technology. To date, Alcatel has shipped more than 80 million DSL lines worldwide.

Market requirements for bandwidth to the subscriber have increased tremendously since the initial deployments of DSL services. Each change in market demand has been anticipated and met with a new technological breakthrough from Alcatel. The Alcatel 7330 ISAM FTTN is part of Alcatel's continued worldwide leadership in broadband innovation.

Answering the challenge to bring more bandwidth closer to the subscriber, service providers are starting the next wave of DSL deployments by increasing the penetration of fiber in access networks. This new deep-fiber access delivers non-blocking, ultra-high bandwidth to each subscriber, enabling the delivery of rich communication and entertainment services. As an evolution toward a full fiber network, FTTN provides the most competitive service.



Taking the Battle to a New Level

IP services in the home are the key to winning the battle against the competition.

HALTING THE SIEGE

Service providers are under siege. Competitive local exchange carriers (CLECs) are in serious competition with incumbent local exchange carriers (ILECs). In addition, cable operators have attacked telecom service providers in the broadband market. At the same time, cable operators are also beginning to compete in the traditional core market of ILECs — voice. In order to survive, telecom service providers must take the battle to a new level.

Broadband technology and the many IP services that it enables create a new battleground for competition in the market place. Those companies that can deploy high-bandwidth connectivity to the customer

and effectively develop and market IP services will win the war.

Telecom service providers have determined that, to be competitive, they must provide bundled services that typically include such things as IP television (IPTV) and other interactive services in addition to high-speed Internet (HSI) and voice. The combination of IP services needed to meet this strategic requirement can increase the required bandwidth to the subscriber from 2 or 3 Mb/s to 20 Mb/s. With Alcatel's VDSL2, up to 25 Mb/s or more can be delivered depending on loop lengths.

The challenge for service providers is to provide additional bandwidth to the subscriber in a cost-effective manner.



Increasing Bandwidth to the Subscriber for Deployment of New Interactive Services

FTTN economically increases available bandwidth to the subscriber while leveraging the existing copper plant.

TECHNOLOGICAL HURDLES

The existing DSL network was engineered to provide HSI access with downstream bandwidth between 0.5 and 2 Mb/s. Competition and increasing usage of the broadband connection have driven HSI bandwidth requirements into the 3 to 8 Mb/s range. Deployment of IPTV service calls for a deep-fiber solution in the access network. Bandwidth requirements for a competitive triple play service require a 20-Mb/s range as illustrated in Figure 1.

Figure 1 - Projected Downstream Bandwidth per Household (Typical IPTV Service)

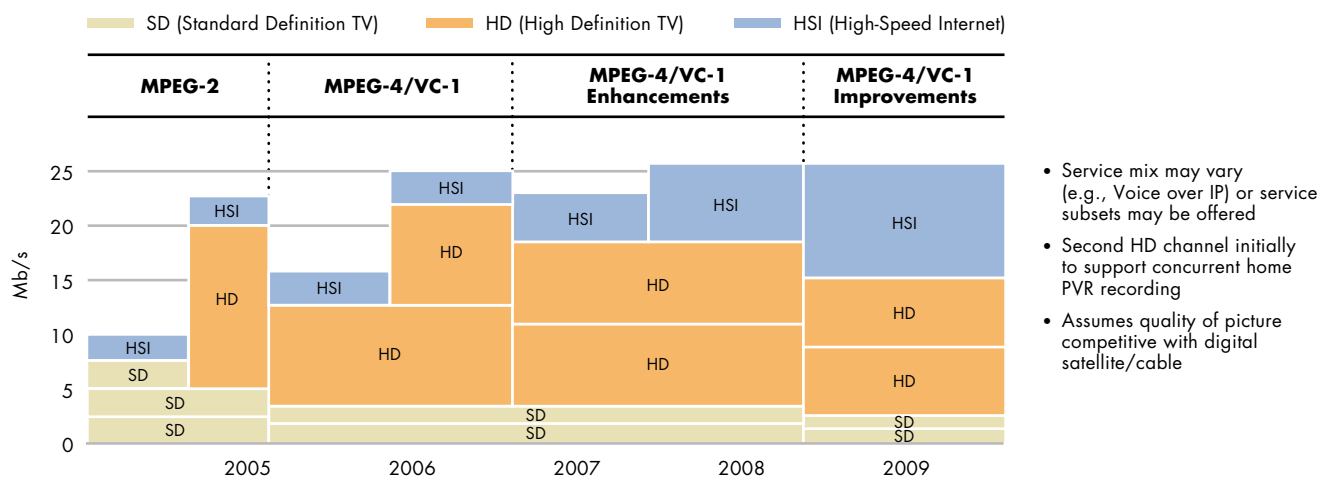

- Service mix may vary (e.g., Voice over IP) or service subsets may be offered
- Second HD channel initially to support concurrent home PVR recording
- Assumes quality of picture competitive with digital satellite/cable

ENCODING RATE ASSUMPTIONS

MPEG-2 SD	MPEG-2 HD	MPEG-4 VC-1 SD	MPEG-4 VC-1 HD	MPEG-4 VC-1 Enh. SD	MPEG-4 VC-1 Enh. HD	MPEG-4 VC-1 Imp. SD	MPEG-4 VC-1 Imp. HD
2.5 Mb to 3 Mb	15 Mb to 19 Mb	1.5 Mb to 2 Mb	10 Mb to 12 Mb	< 1.5 Mb	8 Mb to 10 Mb	< 1 Mb	< 7 Mb

FTTN Leverages Existing Copper Infrastructure

The long-term solution for many service providers is to deploy a fiber-to-the-user (FTTU) solution. This solution enables the service provider to deliver virtually unlimited bandwidth to the subscriber. While this solution is available today and practical in many cases, time-to-market pressures and short-term economic concerns drive an incremental access strategy — FTTN — which leverages the existing copper infrastructure by deploying fiber deep in the outside plant so that copper loop lengths are reduced and DSL bandwidth is increased. This is shown in Figure 2.

As a member of the ISAM family, the Alcatel 7330 ISAM FTTN delivers all services to all customers regardless of the population density and the

reach from the central office (CO). The concepts of flexibility and uniformity lead to simplified operations, minimized operating expenditures (OPEX), minimized training needs and faster time-to-market for new services.

There are several key advantages to FTTN networks:

- > Small footprint and minimal power requirements
- > Reduced right-of-way costs
- > Deep-fiber investment provides an incremental step toward FTTU
- > Seamless integration into existing operations processes, reducing training costs
- > Accelerated deployment, reducing costs and time-to-market while increasing revenues

Coverage and bandwidth needs are answered with Alcatel's self-aggregation concept. The Alcatel 7330 ISAM FTTN is capable of modular growth. The host shelf can be extended in an a distributed way that optimizes the network infrastructure and helps reduce the number of fiber connections to the CO. Fewer fiber connections mean less digging to install fibers and fewer ports required on the switch. The result is a cost-efficient and gradual evolution toward deep-fiber penetration. An additional advantage of this distributed access platform is that it optimizes network management because the distributed system is viewed as one node.

Figure 2 - Leveraging the Existing Copper Infrastructure with FTTN

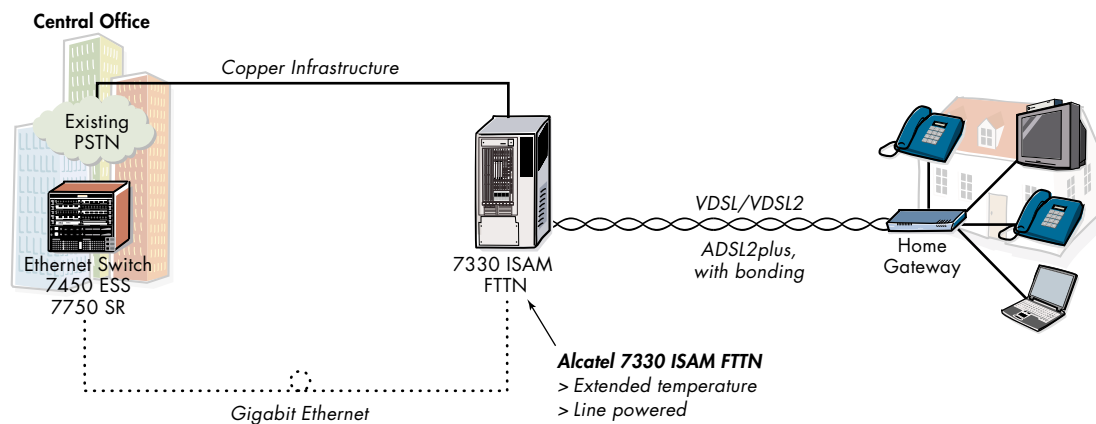

Alcatel 7330 ISAM FTTN — World-Class Technology for World-Class Solutions

The Alcatel 7330 ISAM FTTN is the latest member of the ISAM family. It builds on Alcatel's worldwide DSL expertise by integrating the best technology available from the 7302 ISAM into a more compact remote digital subscriber line access multiplexer (DSLAM) tailored for the unique requirements of FTTN networks.

Figure 3 provides an Alcatel 7330 ISAM FTTN network layout showing a standard area the service provider would cover (the carrier serving area). The CO has an Alcatel 7330 ISAM FTTN host shelf to serve lines that are within the serving area distance of the CO. A remote host is connected to an Alcatel 7330 ISAM FTTN expansion shelf (ES) at one remote site and a sealed expansion

module (SEM) at another remote site. This extends the carrier serving area in a cost-efficient way, allowing modular growth and quick deployment of new services. Another way of extending the coverage is subtending an Alcatel 7330 ISAM FTTN host to an Alcatel 7302 ISAM. The host shelf can be extended with an Alcatel 7330 ISAM FTTN ES or SEM.

To meet the very challenging requirements of an FTTN network, the Alcatel 7330 FTTN has been engineered to support:

- > A non-blocking Ethernet architecture to enable 100 percent take rates of IPTV
- > Expansion shelves and sealed expansion modules to match network population densities

- > Full Internet group management protocol (IGMP) support for multicasting
- > Line-rate IP and Ethernet forwarding via reuse of the 7302 ISAM network processor technology
- > Multiple ADSL line termination (LT) options:
 - ADSL
 - ADSL2
 - ADSL2plus, with bonding
 - READSL2
- > VDSL LT options
 - VDSL
 - VDSL2
- > Gigabit Ethernet (GigE) network interfaces
- > Integration with the Alcatel 5523 ADSL Work Station (AWS) for element management (ETSI)
- > Integration with the Alcatel 5526 Access Management System (AMS) for element management (ANSI)

Figure 3 - 7330 ISAM FTTN Network Layout

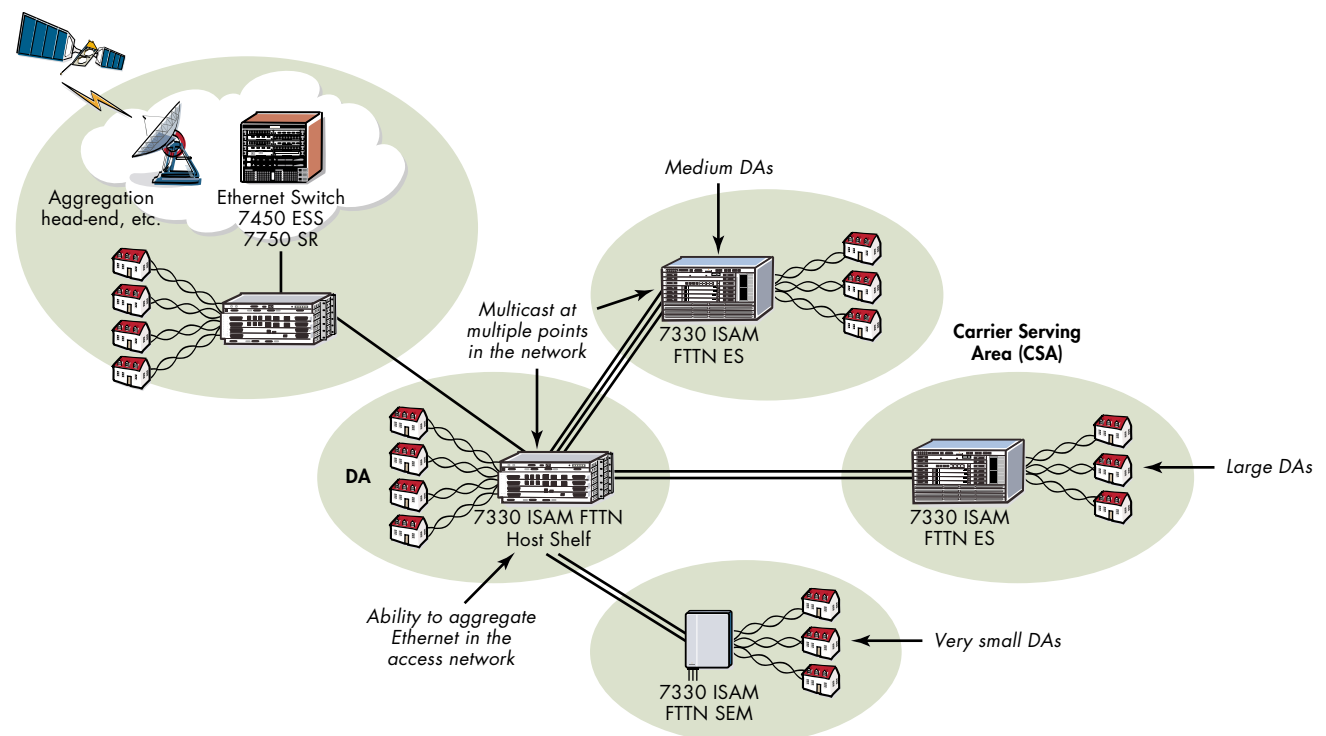

Alcatel FTTN: Multiple Options, One Solution

At the heart of the Alcatel 7330 ISAM FTTN is an Ethernet switch fabric and distributed network processors that were first offered on the Alcatel 7302 ISAM. This high-capacity Ethernet switch fabric is hardened for outside plant deployments and is leveraged across both two-slot and four-slot LT form factors.



7330 ARAM-D

7330 ISAM FTTN (HOST SHELF)

The 7330 ISAM FTTN host shelf contains a high-capacity Ethernet switch. This host shelf supports northbound interfaces to the Ethernet aggregation network. It also provides Ethernet expansion links to expansion modules.

Key features of the 7330 ISAM FTTN host shelf include:

- > High-capacity 24-Gb/s switching fabric and LT architecture, providing non-blocking service to all subscribers at ADSL2plus and VDSL2 line rates
- > Up to seven GigE uplinks, supporting service providers' migration toward Ethernet managed area networks (EMANs) for DSL aggregation
- > Up to ten GigE expansion links for connecting expansion modules
- > Up to four LT cards and four POTS splitter card slots to support up to 192 DSL ports
- > Integration with Alcatel 5526 AMS (ANSI) and Alcatel 5523 AWS (ETSI), for centralized, integrated, in-band management and support of ASAM TL1 parameters

FTTN EXPANSION FOR ADDITION OF SUBSCRIBER INTERFACES

The Alcatel 7330 ISAM FTTN supports expansion modules that have been designed for the addition of subscriber interfaces without the need for additional switching capacity. The Alcatel 7330 ISAM FTTN host, which acts as a central hub for expansion modules, extends GigE interfaces to high-density subscriber interface modules that can be either collocated with the host or remotely deployed and connected with an optical interface.

Figure 4 - 7330 ISAM FTTN Expansion Shelf

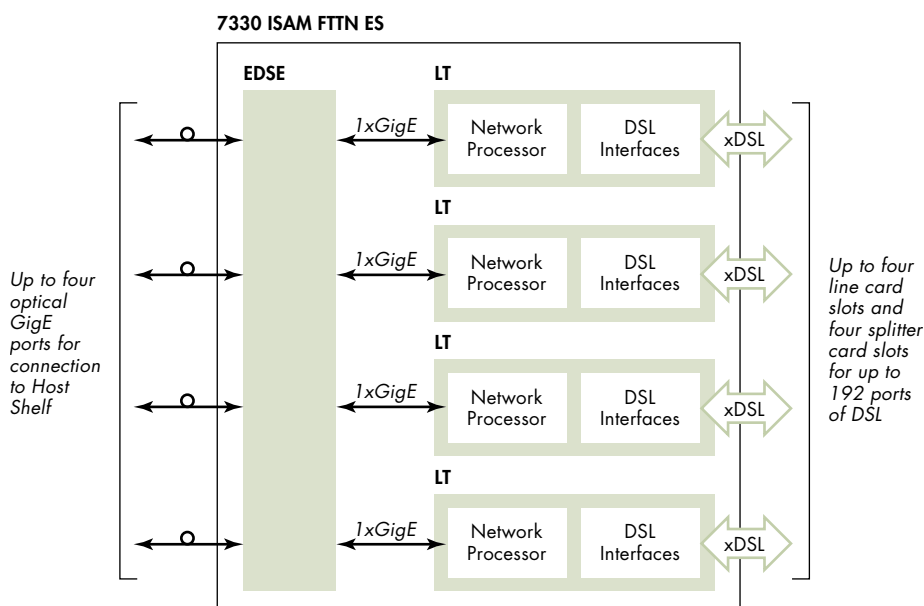

ENABLING EFFICIENT GROWTH

7330 ISAM FTTN Expansion Shelf and Sealed Expansion Module

The Alcatel 7330 ISAM FTTN expansion shelf (ES) is a modular shelf that enables the efficient growth of services and supports up to 192 DSL lines per shelf (as shown in Figure 4). The same ARAM-D shelf used for the host is used for the ES. The expansion shelves can be collocated with a host shelf at a common site or remotely located with the host and expansion shelf at separate sites. In either deployment scenario, the 7330 ISAM FTTN ES uses GigE links to connect to the host shelf.

The 7330 ISAM sealed expansion module (SEM) (Figure 5) is a sealed enclosure than can be mounted directly on the outside of a cabinet. It contains 24 VDSL2 ports that are upgradable to VDSL2 ports by downloading software.

Figure 5 - Sealed Expansion Module Architecture

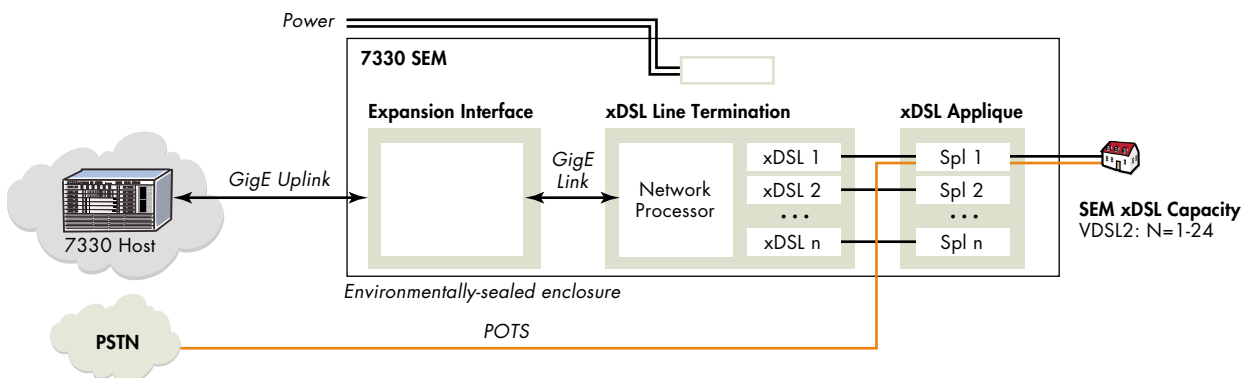

Table 1 - Alcatel 7330 ISAM FTTN Features and Benefits

Feature	Benefit
Member of ISAM family	Flexibility and uniformity lead to simplified operations, minimized OPEX, minimized training needs and faster time-to-market for new services
Distributed architecture	Multiple deployment options fit very small to large distribution areas with the ability to aggregate GigE traffic within the access network; capability to deliver all services to all customers regardless of population density and reach from the CO
GigE interfaces	Economical, high-bandwidth interfaces optimized for IP traffic
Multi-ADSL service unit	LT units, supporting ADSL, ADSL2, ADSL2plus (ITU-T G.992.5) with bonding and READSL2, provide maximum bandwidth to the customer over a wide variety of loop lengths
VDSL service unit	VDSL (ITU-T G.993.1), followed by VDSL2, enables service providers to increase bandwidth to the subscriber to approximately 100 Mb/s
Hardened for harsh environments	Operating temperature range of -40 C to 65 C (-40 F to +149 F)
Ethernet bridging	Layer 2 Ethernet bridge capability provides capacity of up to 24 Gb/s
Multicast support	IGMP and proxy functions (IETF RFC 2236) ensure rapid channel change for IPTV while minimizing the burden of transporting the same content to multiple subscribers
VLAN support	Limits broadcast traffic within the same VLAN broadcast domain to enhance performance while increasing security
Quality of service (QoS)	Implementation of 802.1p priority queues prioritizes data service types, ensuring QoS across IP services, including HSI, video and packet voice
Alcatel 5523 AWS (ETSI)	Full element management for all other Alcatel DSLAM products, optimizing operations and reducing costs
Alcatel 5526 AMS (ANSI)	Support for 7330 ISAM FTTN along with all other Alcatel DSLAM products, for reduced operating costs and ease of deployment of new services

Alcatel Fiber to the Node Answers the Challenge

Alcatel's answer to the FTTN challenge is the Alcatel 7330 ISAM FTTN.

The 7330 ISAM FTTN architecture meets the service providers' challenge by delivering ultra-high bandwidth connectivity to subscribers over the existing copper plant.

With the Alcatel 7330 ISAM FTTN in their arsenal, service providers can halt the competitive siege by rapidly deploying a ubiquitous service offering to their entire subscriber base. Very small to large serving areas can be addressed with multiple form factors of a single Alcatel solution (see Figure 6).

Regardless of the form factor, each 7330 ISAM FTTN supports:

- > A non-blocking, Ethernet architecture with a 24-Gb/s switching fabric
- > Multi-ADSL (ADSL, ADSL2, ADSL2plus with bonding and READSL2)
- > VDSL and VDSL2 services
- > Multicast requirements with IGMP snooping
- > Priority queuing for QoS
- > Full element management through the Alcatel 5526 AMS (ANSI) or the Alcatel 5523 AWS (ETSI)

Figure 6 - Alcatel Fiber to the Node Solution

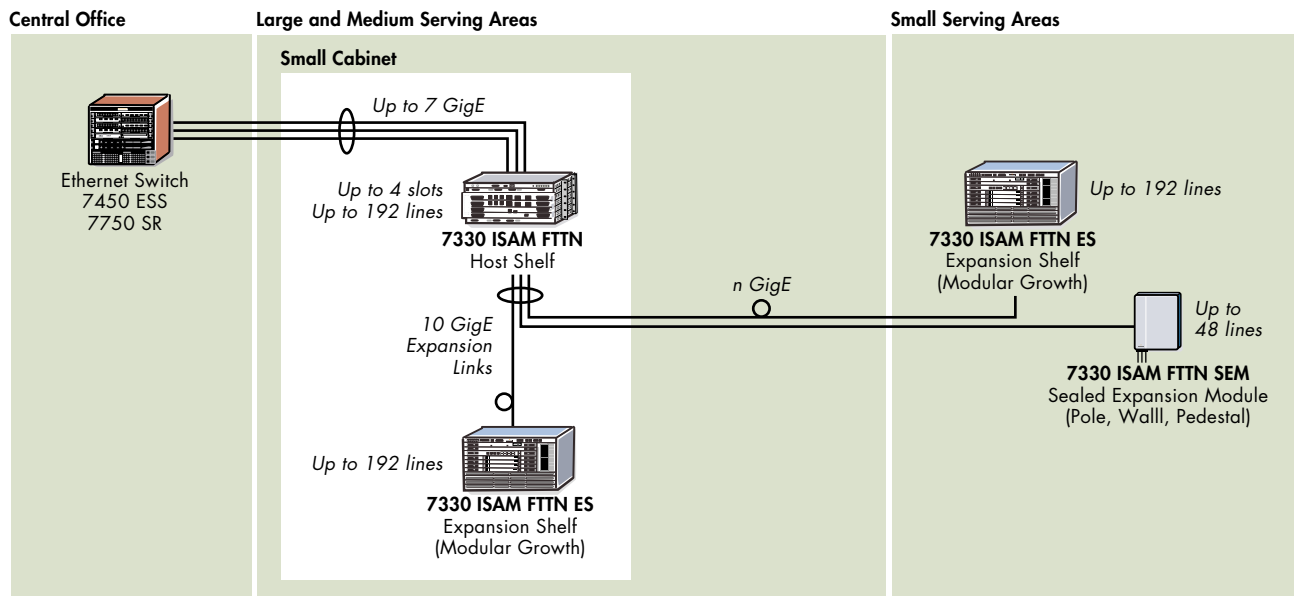

As more and more service providers worldwide prepare for the next wave of broadband deployment — offering a full set of user-centric, personalized triple play services — Alcatel has the solution to meet your deployment requirements.

The Alcatel 7302 Intelligent Services Access Manager (ISAM) is a future-safe, multiservice intelligent access platform for the CO that gives service providers the flexibility of deploying all services to each customer regardless of the customer's access technology.

While the Alcatel 7330 ISAM FTTN addresses the growing need for a deep-fiber access solution, the Alcatel 7340 Advanced Services Access Manager (ASAM) Fiber to the User (FTTU) and the Alcatel 7342 ISAM FTTU expand Alcatel's access portfolio with all-optical access solutions.



7302 ISAM

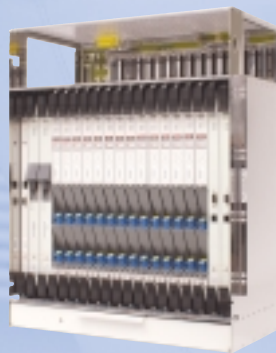

7340 ASAM FTTU



For more information on the Alcatel 7330 ISAM FTTN, please go to www.alcatel.com/7330

www.alcatel.com

Alcatel and the Alcatel logo are registered trademarks of Alcatel.
All other trademarks are the property of their respective owners.

Alcatel assumes no responsibility for the accuracy of the
information presented, which is subject to change without notice.

© 04 2006 Alcatel. All rights reserved. 3CL 00469 0725 TQZZA Ed.04 19797

